Union Tank Car Company – Telematics Vision

- Electronic Environment For Railcars
- Improved Business Process
- Enhanced Safety & Security
- Improved Fleet Management



Union Tank Car Company – Telematics Electronic Environment

- Historically Physical Fields Move to Electrical Fields
 - Manual Power → Mechanical Power → Electronic Power
- Cell Phone
 - 80's Cordless → 90's Cellular → Value Features

Where do we find VALUE?



Union Tank Car Company – Telematics

Improved Business Process

- Better Delivery Scheduling – Real-time Tracking
- Timely Financial Transactions
- Inventory Management:
 - More Precise shipment measurement (Volume & Weight)
 - Electronic linking of inventory into Business Operating System
- Leads to Improved Customer Satisfaction



Union Tank Car Company – Telematics Enhanced Safety & Security

- Immediate Location Known – HAZ MAT & Authority Notification
- Tampering Awareness & Response
- Remote Locking of Manways/Valves – Security Controls
- Gas/Vapor Detection – Potential NARs Detection



Union Tank Car Company – Telematics

Improved Fleet Management – Maximize Uptime

- Detection vs. Inspection
 - Leads to Predictive Measures
- Monitor Life Cycle Costs - Structures/Components
 - Develop history of cost/performance
- Railcar Handling – Impact, Vibration, Stress

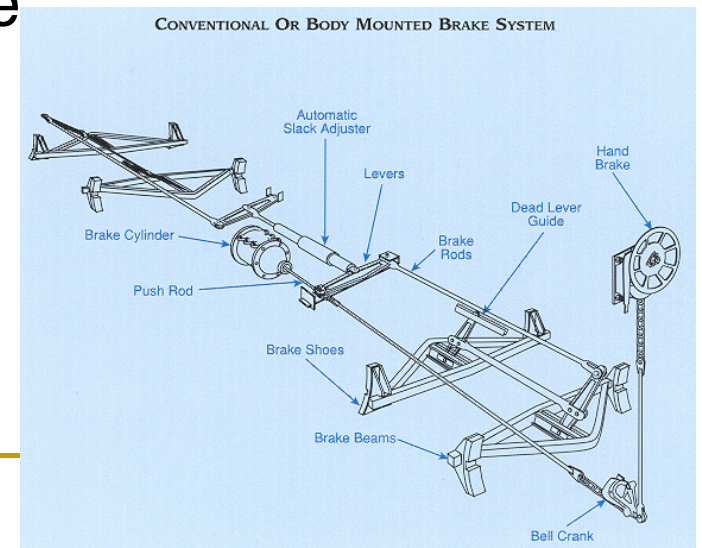
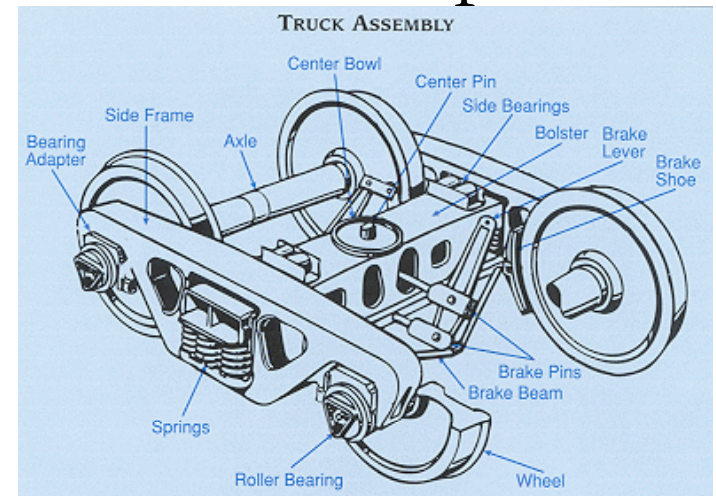

Union Tank Car Company – Telematics

Technical Developments

- On-Board Car Weighing & Volume Systems
- Wireless Sensors
- Lower Power – Longer Life
- Universal OEM Telematic Equipment Mounting

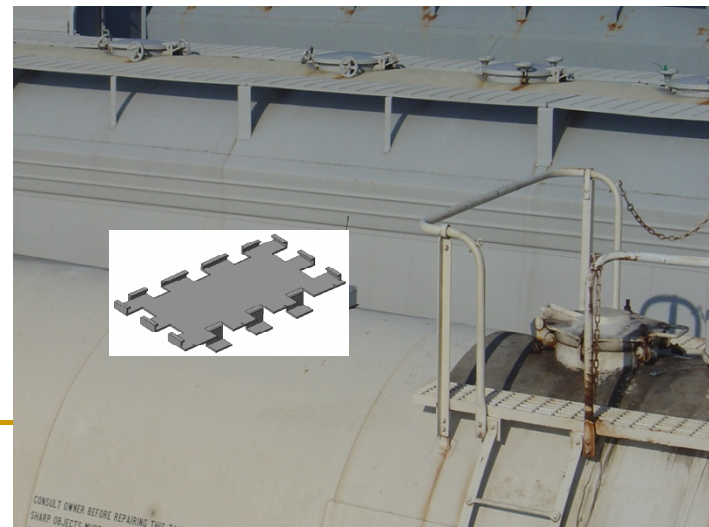
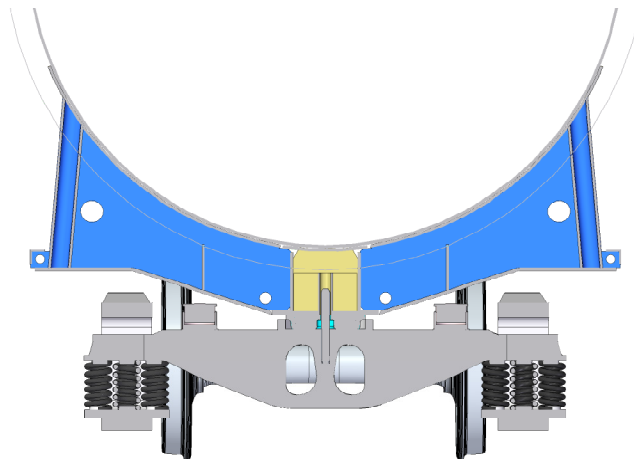

Union Tank Car Company - Telematics

- DHS Update:
 - ❑ Over 580 TIH cars, 6 Shipper Team
 - ❑ Ethylene oxide, Anhydrous Ammonium, Sulfur Dioxide and Chlorine
 - ❑ 40 of 62 HTUA Cities
 - ❑ Begin Installation – October '09
 - 4 to 6 Months
 - ❑ Several Shippers Installing Sensors



Union Tank Car Company - Telematics

Thank You

